

## CONDITION ASSESSMENT

<b>Call Number:</b> N/A	<b>Lab Number:</b> 2015/16-082	
<b>Library/Department:</b> University Archives/Rubenstein Library	<b>Author/Artist:</b> Douglas Chandor	
<b>Librarian:</b> Val Gillispie	<b>Title:</b> Mary Duke Biddle portrait	
<b>Date Examined:</b> 11/3/2015	<b>Publication Date:</b> 1931	<b>Medium:</b> Oil on canvas
<b>Examined by:</b> Beth Doyle	<b>Frame Size:</b> H 93 cm W 82 cm T 9 cm	
<b>Special instructions:</b> Assess condition of oil painting.	<b>Painting Size:</b> H 70 cm W 57 cm T N/A	
<b>Special notes:</b> Condition assessment was done while the painting was on the wall. No report on the description or the condition of the back could be made at the time of this assessment. If, in the future, the portrait is removed from the wall, a condition assessment of the back should be done.		

### \*\*CONDITION REPORT\*\*

#### Description:

- Portrait is an oil painting on canvas.
- The canvas is a medium weave fabric of unknown fiber.
- The oil paint is applied thinly, with some areas with more dense application, especially in the background.
- The frame is wood (unknown species) with gold paint.
- There is no glazing.

#### Condition of Painting (recto):

- The canvas is evenly tensioned across the plane with no distortions or tears.
- The paint is in generally good condition overall.
- There is some crazing on the lower right side above the signature; and upper right corner.
- Overall the painting is rather dark and muted. This likely due to the varnish layer discoloring and years of display grime and dirt on the surface.

#### Condition of Frame (recto):

- The attachment in the frame is good, however, there is slightly more space at the lower right corner.
- All around frame: outer frame is lifting where it meets the inner frame. The gap is as much as 5mm.
- There are many small chips in the frame; large ones are noted below:

#### Condition of Frame (verso):

- Stretcher size: 64 cm W x 76.5 cm H
- Painting is secured in the frame with "Z-hooks" that are stamped "S&W Cat.313"; there are two hooks on each side, eight total. These are screwed into the wooden frame.
- The wooden frame is stamped on the lower left corner, "M. Grieve [LL?]/Hand Carved/New York London"
- There are numerous nail holes in the frame edges
- Label fragment in upper left corner

**Duke University Library  
Conservation Lab  
Perkins Library 023**

- Thumbtack in upper top left corner (not holding anything on)
- Two self-stick white plastic bumpers at the lower edge, attached to the stretcher
- The stretcher is covered with a piece of 2mm thick mat board; this has been stapled to the stretcher all around the edges. At the lower right corner of the mat board is a label "The Frames Studio/Straw Valley 5504 Chapel Hill Blvd./Durham, North Carolina 27707 (919) 493-1339"; under this label is hand written in black ball point ink "painting restored/frame cleaned/ 1-6-1986"
- At the top center and bottom center of the mat board are two holes cut out, lined with linen; Each hole is 4cm W x 3.5cm H. Linen is unbleached (brownish tan).
- Two hangers are at the sides at the top, these are secured 18.5 cm from the top of the frame; they measure 2.5cm W x 4.5 cm H
- At the bottom edge of the frame is "5399 R" in a red pencil; there is a black graphite "26 5/8 [arrow]" on the top right side just above the hanger, and there are pencil lines at the bottom edge of each hanger.
- The stretcher is 4.5cm T
- Condition of verso: frame and stretcher is in good condition. No major cracks. No evidence of pest damage. Very little dust considering how long the painting has been on the wall.

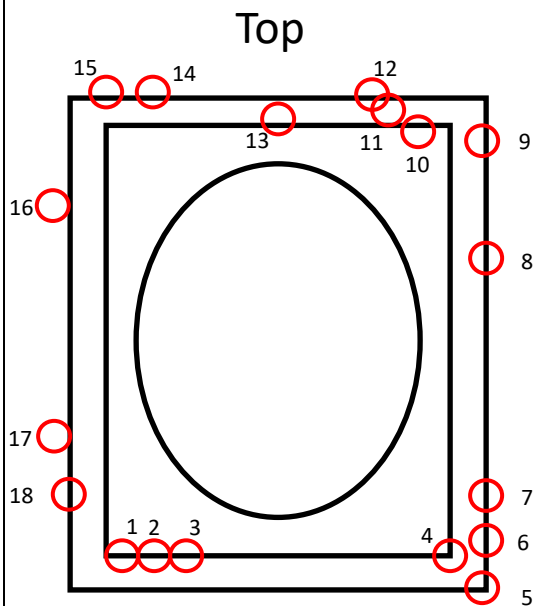

1. Lower left corner: Chip (2 mm x 6 mm) with two small chips to its right. [2015/16-082-bt02]
2. Lower left corner: 9 cm from the lower left corner is a chip (3mm) and another chip (3mm) directly below.
3. Lower left-of-center: Chip (1 cm x 3 mm)
4. Lower right corner: Chip (3 mm x 9 mm)
5. Lower right corner: Damage at back; small chip on corner front.
6. Lower right corner: Chip (1 cm x 4 mm)
7. Right corner: 27 cm from lower right corner is a chip (1 cm x 2 mm)
8. Right side: 37 cm from lower edge is a chip (1 mm x 2 mm)
9. Top right corner: Chip (1 cm x 4 mm)
10. Top right corner: Chip (7 mm x 3 mm)
11. Top right corner (???): two small chips 11 cm from corner
12. Top right corner (???): 21 cm from corner is a chip (4 mm x 5 mm)
13. Top center: Chip (2 mm x 1 mm)
14. Top left: Chip (5 mm x 2 mm)
15. Top left corner: Chip (1 mm x 2 mm) 8 cm from corner
16. Top left side, on back: (2 cm x 3 mm)
17. Left center side, on back: Chip (9 mm x 2 mm)
18. Left side: Chip (1 mm x 4 mm) located 19 cm from bottom left corner

## Conservation issues:

The surface of the painting is dusty; the frame has accumulated thick dust in the carved portions of the frame. The library should consider a dusting schedule for this item, perhaps yearly. Dusting should be done carefully and off the wall so that the back of the painting can be accessed and cleaned.

This painting should be evaluated and treated by a trained paintings conservator. The discolored varnish layer is distracting, and the image very muted. The frame could also benefit from some attention.

Duke University Library  
Conservation Lab  
Perkins Library 023

**\*\*INSPECTION REPORT\*\***

Note changes to the condition of the item (if any) here:

Date Examined:

Examined by: